

# KIT SHOWER C1

**HERRATEK**  
Solutions for windows and doors



## Piezas



Datos Técnicos	
Modelo	F / C / C / F
Material	Aluminio
Rodamiento	Súper resistente a la fricción y desgaste
Carga por rodamiento	30 kg x hoja
Disponible	Templado de 6mm

Acabado	Medida	Código
Pulido brillante	0.90 m	03KB00080
	1.20 m	03KB00081
Negro Mate	0.90 m	03KB0080B
	1.20 m	03KB0081B

Tabla de Descuentos		
Línea Eje A	Und.	Corte
Riel Superior - Inferior	02	B - 14
Jamba	01	H - 2
Tapa	02	B/2 - 15
Vidrio Móvil 6 mm	01	B/2 - 5 / H-22
Vidrio Fijo 6 mm	01	B/2 - 5 / H-72

Línea Eje B	Und.	Corte
Riel Superior - Inferior	02	B - 14
Jamba	01	H - 2
Tapa	02	B/2 - 15
Vidrio Móvil 6 mm	01	B/2 - 5 / H-22
Vidrio Fijo 6 mm	01	B/2 - 5 / H-72

Expresado en milímetros

## Descuento de vidrio

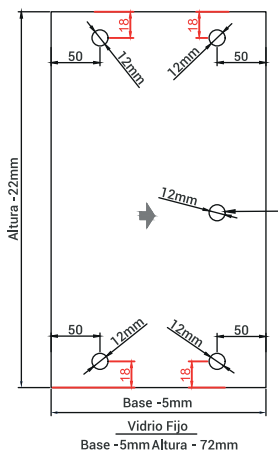

## Modelo

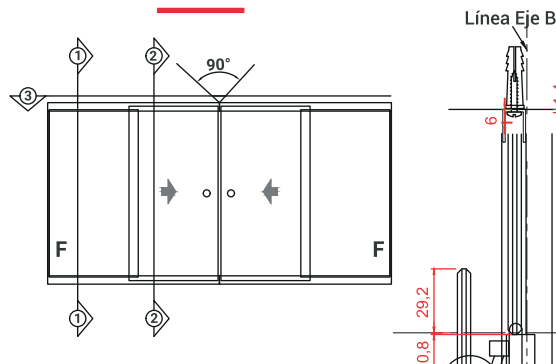

## Plano de corte

